

Hettich Slide-on



Great hinge
with **clear** benefits

Hettich Slide-on

Great hinge with clear benefits





Apart from anything else, Hettich's hinge scores points for quality and environmental awareness. Tested quality ensures full functionality for a long service life – after which the all-steel hinge can be fully recycled.



**"Hettich Direkt"
for strength down the middle**

Hettich mounting plates offer many benefits, increase design freedom and help to cut assembly costs.

The Hettich Direkt mounting plate – ideal for fixing to centre panels from 15 mm thick – is a case in point. The pilot dowels for the hole line and asymmetrically positioned screw significantly improve tear-out strength, particularly on thinner centre panels. And it's a safe bet that the Hettich Direkt wing mounting plate is equally good for other mounting applications.

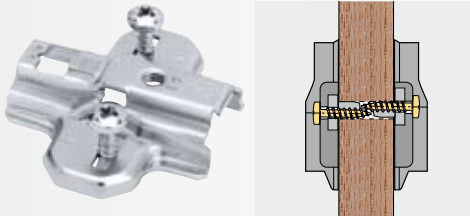

The quality of our hinges is monitored continuously. Hettich hinges comply with the national and international quality standards of the markets our customers operate in.

Concealed hinges

Technical information

Mounting options:

There are three basic methods for mounting doors.

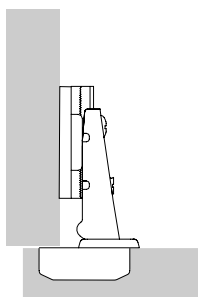

Full overlay:

In this configuration, the door is positioned in front of a side wall of the cabinet. The reveal at one side is such that the door can be opened safely.

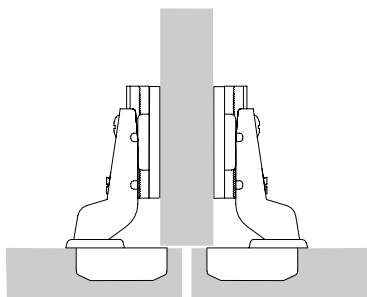

Half overlay:

In this configuration, two doors are positioned in front of the middle wall of a cabinet. The distance between the doors is the total required reveal. The reduced door overlay necessitates the use of cranked hinges.

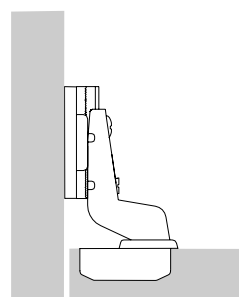

Inset:

In this configuration, the door is positioned inside the side wall of the cabinet. A reveal is required for opening the door. This configuration necessitates the use of heavily cranked hinges.

Minimum door reveal:

The reveal, also called door deflection, is the space required for opening a door. The amount of reveal depends on the cup distance C, the door thickness and the hinge type. Chamfered door edges reduce the reveal. The required minimum reveal can be read from the table given for each hinge type. For half overlay configurations, the total reveal between the doors must be at least twice the door reveal. Both doors can then be opened at the same time.

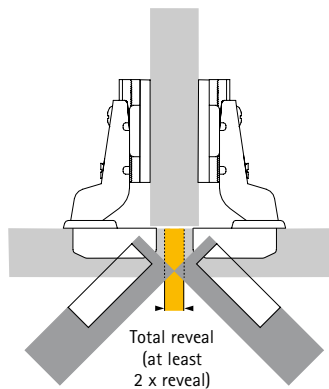
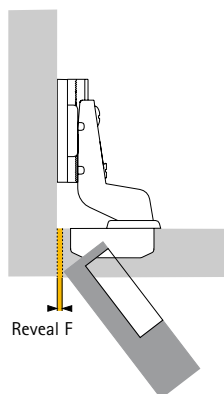



Cup distance C:

The cup distance C is the distance between the edge of the door and the edge of the cup hole. The maximum cup distance depends on the kinematics of the hinge in question. The larger the cup distance, the smaller the required minimum reveal.

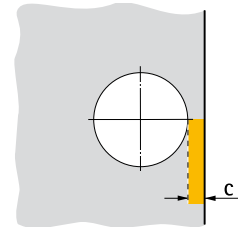

Door overlay:

The door overlay is the distance that the door extends over the front edge of the side panel.

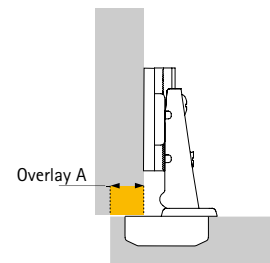

Reveal F:

The reveal F is the distance between the outer edge of the door and the outer edge of the side panel (full overlay), the distance between two doors (half overlay), the distance between the outer edge of the door and the inner side panel (inset).

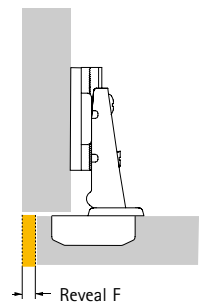

Number of hinges per door:

Door width, door height, door weight and door material are the key factors for determining the required number of hinges.

In practice, these factors are very variable. The numbers listed in the diagram are for reference only. A trial mounting is recommended if in doubt.

Maximum stability is obtained by choosing the distance between hinges as large as possible.

X = distance between two hinges
(reference values for 19 mm thick chipboard with a density of 750 kg/m³)

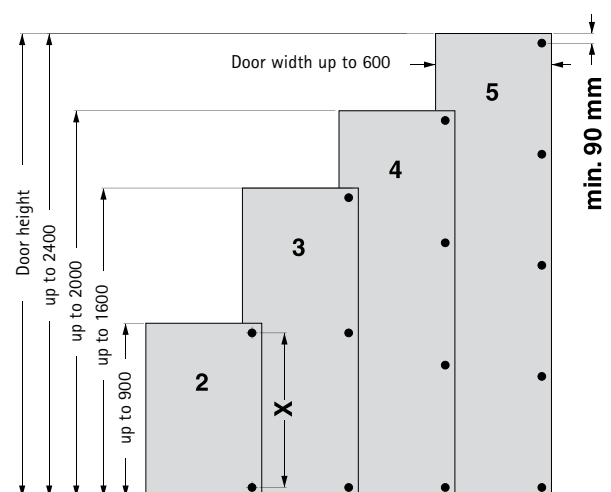

Technical information

Distance D:

Mounting plates are available in various thicknesses with an effective height characterized by the value of the distance D. Starting point for calculating the required distance is the selected hinge with defined door overlay.

Using planned cup distance and door thickness, first read the required reveal value from the table. If this value is too large for the desired overlay, it can be reduced, either by increasing the cup distance, or by chamfering the door edge. Then the mounting plate distance is determined using the relevant hinge cranking formula.

Example:

Centre panel door,
total reveal between doors 5 mm

2333 hinge with 9.5 cranking

Centre panel thickness 16 mm, door thickness 22 mm,
nominal cup distance 3 mm

1. **Table shows minimum reveal: 3.1 mm**, ie, the total reveal should be at least 6.2 mm. But you want a total reveal of 5 mm. So increase the cup distance to 4 mm. The table now shows a minimum reveal of 2.8 mm, giving a total reveal of 5.6 mm. In addition, chamfer the door edges to a 1 mm radius. This reduces the minimum reveal as shown in the table from 2.8 to 2.4 mm, or the total reveal from 5.6 to 4.8 mm.

2. **Door overlay A** = $(\text{panel thickness} - \text{reveal}) / 2 \text{ doors} = (16.0 \text{ mm} - 5.0 \text{ mm}) / 2 = 5.5 \text{ mm}$

3. The formula for calculating the distance D for a hinge with 9.5 mm cranking:

$$\text{Distance D} = \text{cup distance C} + 5.0 \text{ mm} - \text{overlay A} = 4.0 \text{ mm} + 5.0 \text{ mm} - 5.5 \text{ mm} = 3.5 \text{ mm}$$

If the calculated distance value is not listed (see page 10/11), select the next smaller distance.

In this example, a distance of 3.0 mm is selected. The hinge is then set at 0.5 mm using the side adjustment.

Door adjustment:

Hettich Slide-on hinges offer all the benefits of three-dimensional adjustability (vertical, lateral and depth) to get doors perfectly aligned.

Side adjustment

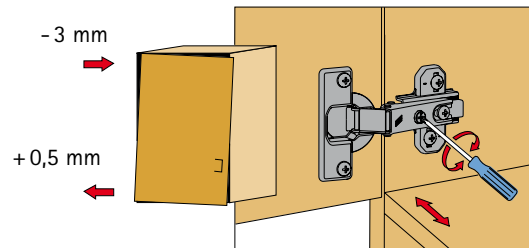

Turn screw **clockwise**: door overlay **decreases** (-)
Turn screw **anticlockwise**: door overlay **increases** (+)

Height adjustment

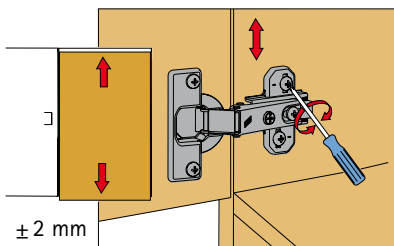

Loosen the mounting plate screws and adjust the door height. Then retighten the screws.

Cam depth adjustment

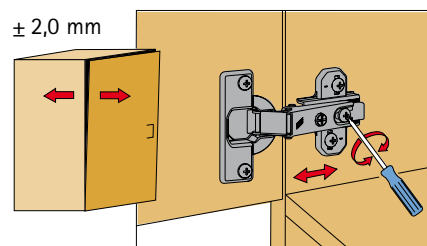

Loosen the screw and adjust the gap between door and cabinet. Then retighten the screw.



Hettich-Direkt

The **Hettich-Direkt** mounting plate is ideal for **centre panels from 15 mm thick**.

The **premounted pilot dowels** are simply inserted in the **ø5 mm hole line**. The mounting plate is thus held firmly even before it is finally screwed on.

This simplifies assembly both on centre panels and side panels.

The **special premounted screws are offset**. This is important so that, on centre panels, they do not make contact with the screw from the other side.

This patented solution makes it feasible to use longer screws with better tear-out values even on centre panels. A high tear-out value makes for improved safety in daily use.

Oval holes in the mounting plate allow scope for the full height adjustment.

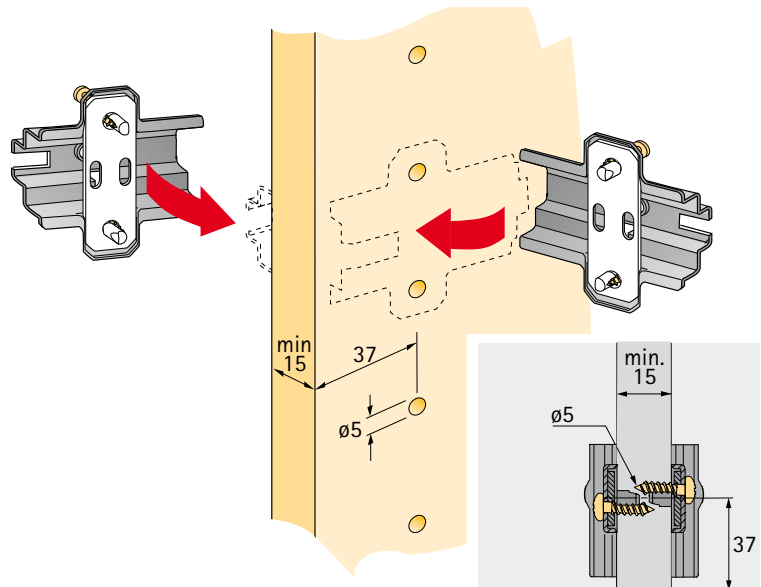

Assembly/Disassembly Slide-on

Slide the side arm of the hinge under the premounted screw on the mounting plate (1) and push home.

Adjust the gap between door and panel and tighten the screw (2).

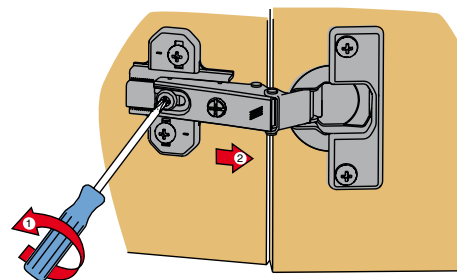
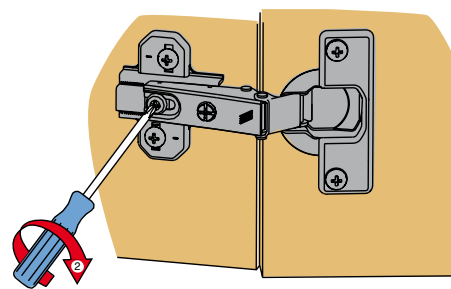
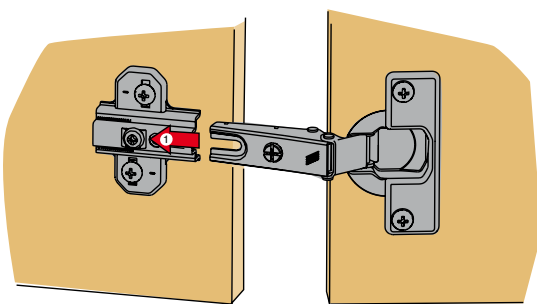

Disassemble the hinge in reverse order.

Hettich Slide-on

Slide-on hinge

Opening angle 95°

Hettich Slide-on 2333



Full overlay door
0 mm cranking



Half overlay door
9.5 mm cranking



Inset door
16 mm cranking

Cup assembly

self-closing
2333



self-closing
2333

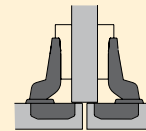

self-closing
2333

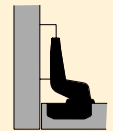

Screw-on
T 42

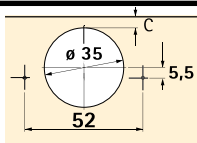

107 866 0

107 866 1

107 866 2

Screw-on
T 42/24
(Premounted
chipboard screws)

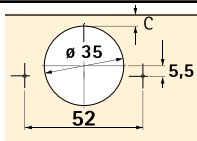

108 083 4

108 083 5

108 083 6

Screw-on
T 42/27
(premounted
turbo screw)

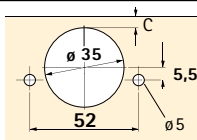

901 090 9

901 091 2

901 091 3

Press-in
T 43

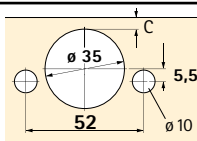

107 866 3

107 866 4

107 866 5

T 42/48

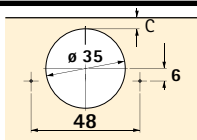

108 492 7

108 493 2

108 493 7

T 42/54
(premounted
turbo screw)

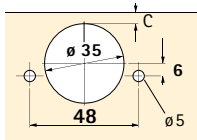

903 839 6

903 839 8

903 839 9

T 42/10

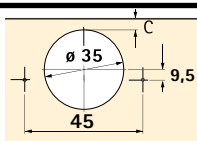

903 703 4

903 734 9

903 735 1

Opening angle: 95°
 Hole diameter: 35 mm
 Cup distance C: up to 6 mm
 Cup depth: 11,1 mm
 Self-closing feature: with 

Side adjustment: + 0,5 mm/- 2,5 mm
 Depth adjustment: + 2,0 mm/- 2,0 mm
 Packing unit: 200 psc

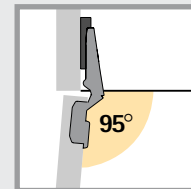

Minimum door reveal (F) per door:

For calculating the cup distance and mounting plate distance

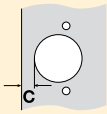
Cup distance C mm		Door thickness mm									
		16	17	18	19	20	21	22	23	24	25
3		0,6	0,8	1,1	1,5	1,9	2,4	3,1	4,0	4,8	5,8
4		0,5	0,7	1,0	1,4	1,8	2,3	2,8	3,5	4,3	5,3
5		0,2	0,4	0,8	1,3	1,7	2,2	2,7	3,3	4,0	4,8
6		0,0	0,3	0,7	1,3	1,6	2,0	2,5	3,2	3,8	4,5

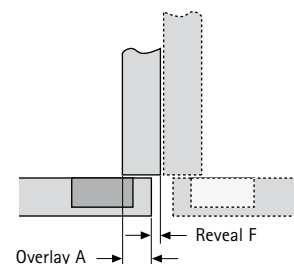

The minimum reveal is reduced for doors with radius:
 1 mm radius: table entry - 0.4 mm
 3 mm radius: table entry - 1.2 mm

Calculating the required mounting plate distance (D):

Depends on door overlay (A) and cup distance (C)

Full overlay
 (0 mm cranking)*

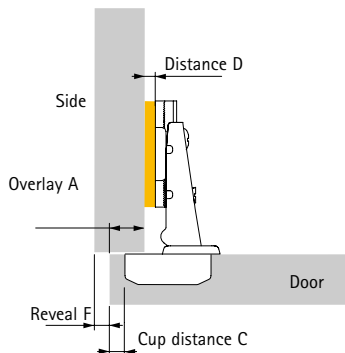

Distance D =
 Cup distance C + 14.5 mm - overlay A

Half overlay
 (9.5 mm cranking)

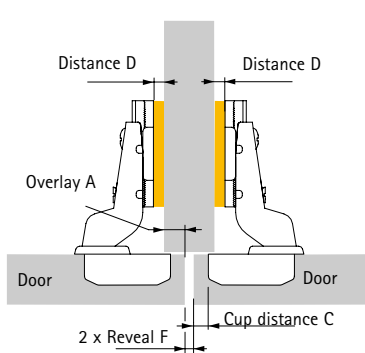

Distance D =
 Cup distance C + 5.0 mm - overlay A

Inset
 (16 mm cranking)

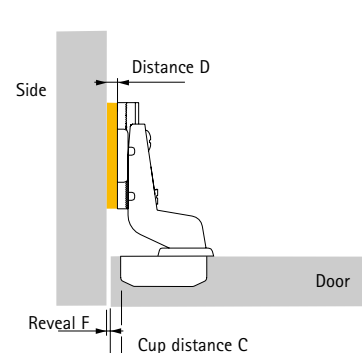

Distance D =
 Cup distance C - 1.5 mm + reveal F

* 0 mm cranking cannot be used in combination with a 0 mm mounting plate distance

For mounting plates refer to page 10 - 11

Door protrusion (T), hinge protrusion (B), hinge installation depth (H):

	Hinge cranking (mm)		
	K 0 mm (full overlay)	K 9,5 mm (half overlay)	K 16 mm (inset)
T* (mm)	6,0	15,5	22,0
B* (mm)	19,0	28,5	35,0
H** (mm)	54,5	54,5	54,5

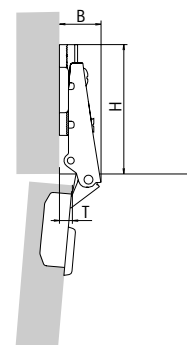

*) Measurements refer to a mounting plate with 1.5 mm distance and 3 mm cup distance. If the value for distance changes, the values T and B change accordingly.

**) The installation depth is measured from the inside door face.

Mounting plate system 2006 K

Packing unit: 400 pcs

Item

Screw-on wing mounting plate

with oblong holes \varnothing 4.0 mm; hole spacing 32 mm

Mounting: countersunk panel screws

Height adjustment: +2/-2 mm

Material: nickel-plated steel

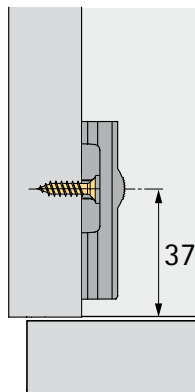

Hole line	Distance (D)	Total height	Order no.
37 mm	0 mm	6,5 mm	107-919-7*
	1,5 mm	8,0 mm	107-919-8
	3,0 mm	9,5 mm	107-919-9
	5,0 mm	11,5 mm	107-920-0

*) not suitable for 2333 KO

Screw-on wing mounting plate

with oblong holes and premounted Euro screws; hole spacing 32 mm

Mounting: premounted Euro screws

Hole: \varnothing 5 mm x 12 mm

Height adjustment: +2/-2 mm

Material: nickel-plated steel

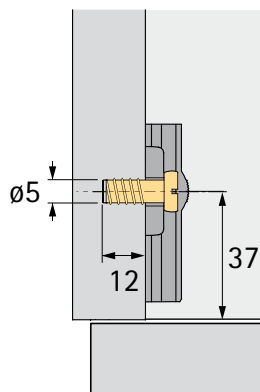

Hole line	Distance (D)	Total height	Order no.
37 mm	0 mm	6,5 mm	107-922-1*
	1,5 mm	8,0 mm	107-922-2
	3,0 mm	9,5 mm	107-922-3
	5,0 mm	11,5 mm	107-922-4

*) not suitable for 2333 KO

Mounting plate system 2006 K

Packing unit: 400 pcs

Item

Hettich-Direkt screw-on wing mounting plate

with oblong holes; hole spacing 32 mm

Mounting: pilot dowel and asymmetrically premounted wood screws

Hole: \varnothing 5 mm x 7.5 mm

Height adjustment: +2/-2 mm

Material: nickel-plated steel

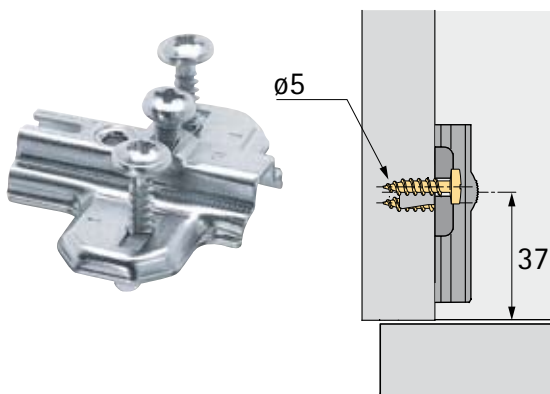

Hole line	Distance (D)	Total height	Order no.
37 mm	0 mm	6,5 mm	not available
	1,5 mm	8,0 mm	107-921-0
	3,0 mm	9,5 mm	107-921-1
	5,0 mm	11,5 mm	107-921-2

Cover cap



Colour	Order no.	PU
black	903 736 5	2500
grey	904 094 7	2500



Hettich Marketing- und Vertriebs GmbH & Co. KG
P.O. Box 1240 · 32269 Kirchlengern · Germany · Phone +49 05223 77-0 · E-mail: info@de.hettich.com
www.hettich.com